

# ECLIPSE HOT-AIR BUTTERFLY VALVES

SERIES "HBV"

Bulletin 722

5/83

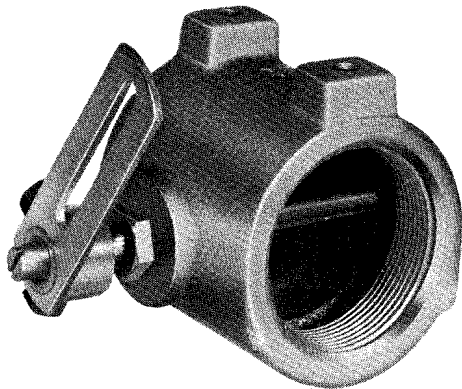

**MANUAL HOT-AIR BUTTERFLY VALVE**

Eclipse Hot-Air Butterfly Valves are designed for high-low or modulating air flow control in combustion systems using pre-heated combustion air. They are not to be considered tight shut-off valves. They are capable of controlling air flow up to a maximum operating temperature of 600° F. under pressures up to 5 psi. Cast iron bodies tapped for standard pipe threads, mild steel shutters, stainless steel shafts and a graphite packing compound combine to provide accurate, dependable and durable operation.

When selecting an Eclipse Hot-Air Butterfly Valve for high-low control, its pipe size should match the pipe size of the air manifold in order to minimize pressure drop through the valve. For modulating control, select the Hot-Air Butterfly Valve with a pressure drop equal to about 15% of the inlet pressure to the valve.

Used manually as a balance valve for air flow in multi-burner systems, the Hot-Air Butterfly Valve may be adjusted by placing a screwdriver in the slot on the end of the shaft and turning the shaft. Once the desired air flow is attained, the valve may be set for that flow by tightening the packing nut enough to prevent shaft rotation under maximum air flow conditions. The slot on the shaft indicates shutter position in both manual and automatic applications.

For automatic operation, Hot-Air Butterfly Valves can be furnished with a mounting bracket and linkage for most types of electric or pneumatic control motors, or they can be furnished complete with control motor. The shaft length allows the addition of a second control arm for simultaneous,

automatic operation in dual valve applications. When the valve is used with a control motor, the packing nut should be tightened enough to subject the shaft to 15-20 inch pounds of torque. In automatic applications where the control motor is to be mounted on the high-temperature butterfly valve and air temperature through the valve exceeds 150° F., an extension support is required. The extension support (#500829) is made of welded, low-carbon steel and helps prevent control motor damage by elevating the control motor approximately 6" away from high temperature air flow through the valve (see photograph below). The top mounting surface of the extension support is designed to accommodate all types of control motor mounting brackets.

Whether the intended application involves manual or automatic operation, all Eclipse Hot-Air Butterfly Valve assemblies listed are furnished with one control arm (see photograph top left) and are available in 2", 2½", 3", and 4" pipe sizes.

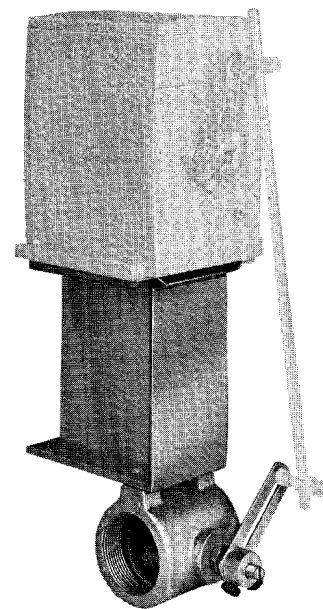

**AUTOMATIC HOT-AIR BUTTERFLY VALVE**

## CAPACITIES

CATALOG NUMBER	ASSEMBLY NUMBER	PIPE SIZE	FLOW COEFF. (CV) FULL OPEN	AIR CAPACITY SCFH @ 600° F. - AIR/INCHES W.C. DROP*										
				1"	1.5"	2"	3"	4"	6"	8"	10"	12"	16"	
8 HBV-A	500530	2"	340	10,600	13,000	15,000	18,300	21,200	25,800	29,700	33,100	36,200	42,400	
10 HBV-A	500531	2-1/2"	438	13,550	16,600	19,200	23,400	27,100	33,000	38,200	42,600	46,600	54,200	
12 HBV-A	500532	3"	695	21,500	26,500	30,700	37,400	43,000	53,000	60,900	68,000	74,400	86,000	
16 HBV-A	500533	4"	1500	47,000	57,000	66,000	80,000	94,000	114,000	132,000	147,000	160,000	188,000	

\*When using air other than 600° F., apply multifactor to above capacities.

TEMPERATURE	500°F	400°F	300°F	200°F	60°F
MULTIFACTOR	1.05	1.11	1.18	1.27	1.41



Eclipse Combustion

## DIMENSIONS

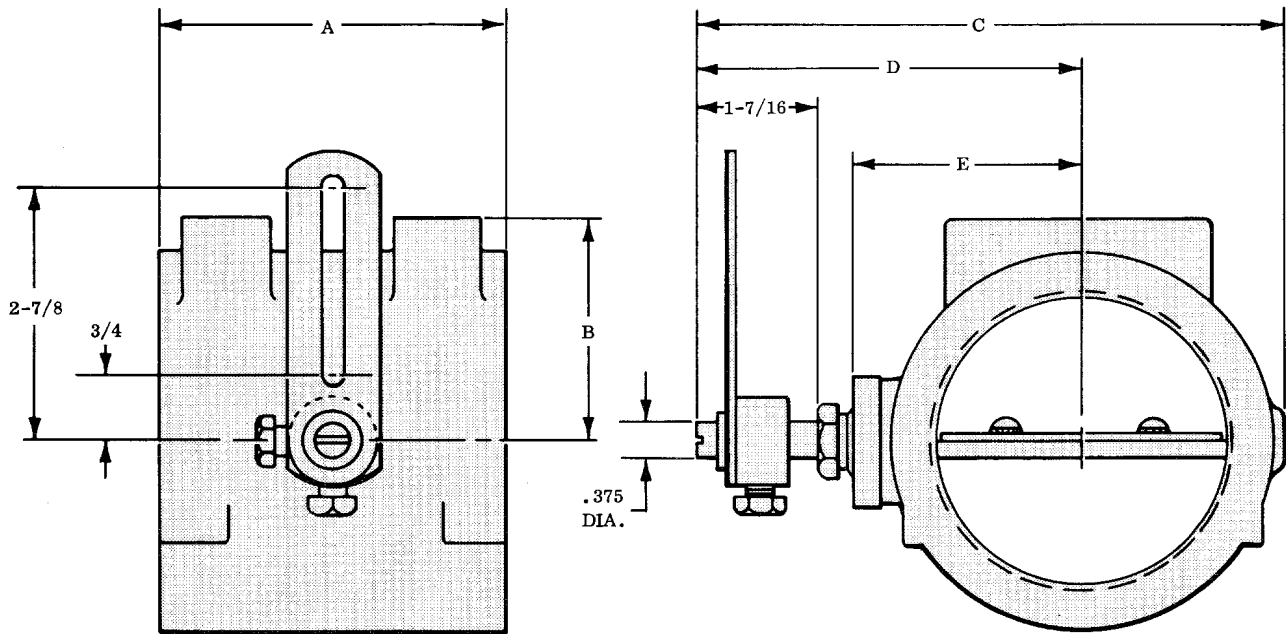

CATALOG NUMBER	PIPE SIZE	DIMENSIONS					APPROX. SHIP. WT. IN LBS.
		A	B	C	D	E	
8 HBV-A	2	3-1/8	1-15/16	5-7/16	3-11/16	1-15/16	3-3/4
10 HBV-A	2-1/2	3-7/8	2-1/4	6-1/16	4-1/16	2-5/16	6-1/2
12 HBV-A	3	3-7/8	2-1/2	6-9/16	4-5/16	2-9/16	7
16 HBV-A	4	5	3-1/16	7-11/16	4-7/8	3-1/8	12

Note: All dimensions are in inches.



*Eclipse Combustion*

Litho in U.S.A.



**Offered By:**

Power Equipment Company  
2011 Williamsburg Road  
Richmond, Virginia 23231  
Phone (804) 236-3800  
Fax (804) 236-3882

---

[www.peconet.com](http://www.peconet.com)